

# TOWN OF LENOX/VILLAGE OF WAMPSVILLE

205 S. Peterboro St. Canastota, NY 13032  
Josh Stagnitti Code Enforcement Officer  
Town of Lenox Office: 315-697-5575 / Fax: 315-697-5514  
E-Mail: [tolcodes@cnyemail.com](mailto:tolcodes@cnyemail.com) / [www.lenoxny.com](http://www.lenoxny.com)

## DECK BUILDING AND ZONING PERMIT APPLICATION

### INSTRUCTIONS

- A. All applications **must** be typewritten or printed and completed in ink and submitted to the Code Enforcement Officer.
- B. All applications must include a site plan. Locate clearly and distinctly all buildings, with size dimensions, whether existing or proposed and indicate all setbacks with dimensions from property lines and existing and proposed deck. Give lot dimensions according to deed and show location and name of address and street. (See Zoning Permit instructions.)
- C. Upon the approval of the application, the Code Enforcement Officer will issue the building permit to the applicant together with approved duplicate sets of plans and specifications. Such permit and approved plans and specifications remain on the premises available for inspection throughout the progress of the work.
- D. The Owner or Contractor shall notify the Code Enforcement Officer when work is ready for inspection as outlined in the inspection schedule issued with permit.
- E. NO DECK SHALL BE USED FOR ANY MEANS UNTIL THE CODE ENFORCEMENT OFFICER HAS GRANTED A CERTIFICATE OF COMPLIANCE.
- F. All electrical work must be inspected by, and a Certificate of Approval is obtained from a third party electrical inspection agency. No certificate of Occupancy will be issued until electrical work has been inspected and approved.
- G. THE TOWN OF LENOX SHALL USE ANY OR ALL GUIDELINES SET FORTH BY THE NEW YORK STATE UNIFORM BUILDING AND FIRE CODES AND MANUFACTURERS GUIDELINES.

Note: If you have any questions call:  
Josh Stagnitti  
Code Enforcement Officer  
Town of Lenox  
205 S. Peterboro St.  
Canastota, New York 13032  
697-5575 Office  
697-5514 Fax  
E-Mail: [tolcodes@cnyemail.com](mailto:tolcodes@cnyemail.com)

#### Office Hours

Monday Thru Friday

8:00 a.m. To 4:00 p.m.





**Town of Lenox / Village of Wampsville  
Code Enforcement Office**  
 205 S. Peterboro Street, Canastota, NY 13032  
 E-Mail: [tolcodes@cnymail.com](mailto:tolcodes@cnymail.com) / [www.lenoxny.com](http://www.lenoxny.com)  
 Josh Stagnitti Code Enforcement Officer  
 Office: 315-697-5575 Fax: 315-697-5514

## DECK PERMIT APPLICATION

**1. Project Location and Information**

- a. Number and Street Address: \_\_\_\_\_
- b. Tax Map Number: \_\_\_\_\_
- c. Current use of premises: \_\_\_\_\_
- d. Proposed use of premises: \_\_\_\_\_

**2. Owner Identification**

- a. Owners name: \_\_\_\_\_
- b. Owners Address: \_\_\_\_\_
- c. Phone number: \_\_\_\_\_
- d. Email: \_\_\_\_\_

**3. Type of Construction or Improvement**

- New Building – Proposed Use : \_\_\_\_\_
- Conversion –Current Use: \_\_\_\_\_ Proposed Use: \_\_\_\_\_
- Addition       Alteration       Repair or Replacement
- Relocation       Demolition       Misc. Structure or Equipment

**4. Description of project:**

\_\_\_\_\_  
 \_\_\_\_\_  
 \_\_\_\_\_

**5. Estimated Project Cost:**

\_\_\_\_\_

Official Use Only	
Date Received: _____	Received By: _____
Special Review By: <input type="checkbox"/> ZBA <input type="checkbox"/> Planning BD <input type="checkbox"/> Historic Review	
Date Issued: _____	Approved By: _____
PERMIT NUMBER: _____	

Designers and Contractors Information

1. **Architect or Engineer:**

---

---

2. **General Contractor:**

---

---

3. **Electrical Contractor:**

---

---

4. **Plumbing Contractor:**

---

---

5. **Mechanical Contractor:**

---

---

6. **Other Contractor:**

---

---

**MUST SUBMIT WORKERS COMPENSATION, DISABILITY INSURANCE  
CERTIFICATES AND ACCORD SHEETS FOR ALL CONTRACTORS.**

NOTES:

**IMPORTANT NOTICES: READ BEFORE SIGNING!**

1. Work conducted pursuant to a building permit must be visually inspected by the Code Enforcement Officer and must conform to the documents submitted, New York State Uniform Fire Prevention and Building Code and all applicable codes, rules and regulations.
2. It is the owner's responsibility to contact the Code Enforcement Office at 697-5575 at least 48 hours before any requested inspection. **DO NOT PROCEED TO THE NEXT STEP OF CONSTRUCTION UNTIL INSPECTIONS HAVE BEEN COMPLETED.** Otherwise, work may need to be removed at the owners or contractors expense to conduct the required inspections. Close coordination with the Code Enforcement Office will greatly reduce this possibility.
3. **THE OWNER HEREBY AGREES TO ALLOW THE CODE ENFORCEMENT OFFICER TO INSPECT THE SUFFICIENCY OF THE WORK BEING DONE PERSUANT TO THIS PERMIT, PROVIDED HOWEVER, THAT SUCH INSPECTIONS ARE LIMITED TO THE WORK BEING CONDUCTED PURSUANT TO THIS PERMIT AND ANY OTHER NON WORK RELATED VIOLATIONS WHICH ARE READILY DISCERNIBLE FROM SUCH INSPECTIONS.**
4. New York State Law requires contractors to maintain Worker's Compensation and Disability Insurance for their employees. No permit will be issued unless a currently valid Worker's Comp and Disability Insurance certificate is attached to this application. If the contractor believes that they are not required to have the described insurance then the contractor must complete form C-105.21, attached hereto.
5. If a certificate of occupancy is required, the structure shall not be occupied until such certificate has been issued.
6. Work undertaken pursuant to this permit is conditioned upon and subject to any state and federal regulations relating to asbestos materials.
7. The building permit card must be displayed so as to be visible from the street nearest to the site of the work being conducted.

I \_\_\_\_\_, the above named applicant, hereby attest that I am the lawful owner or agent of the property described within and affirm under penalty of perjury that all statements made by me on this application are true.

(Signature) x \_\_\_\_\_ Date: \_\_\_\_\_

(Print Name) \_\_\_\_\_

(Title) \_\_\_\_\_

# ZONING PERMIT

APPLICATION NUMBER: \_\_\_\_\_

ISSUE DATE: \_\_\_\_\_

APPROVED BY: \_\_\_\_\_

ISSUED BY: \_\_\_\_\_

SIGNED:

SIGNED:

X \_\_\_\_\_  
Zoning Officer

X \_\_\_\_\_  
Administration

VARIANCE DATE: \_\_\_\_\_

ZONING DISTRICT: \_\_\_\_\_

OFFICIAL USE

DATE: \_\_\_\_\_

TAX MAP NUMBER: \_\_\_\_\_

ADDRESS OF JOB SITE: \_\_\_\_\_

NATURE OF WORK: \_\_\_\_\_

PROPOSED USE: \_\_\_\_\_

EXISTING USE: \_\_\_\_\_

PROPERTY OWNERS NAME: \_\_\_\_\_

ADDRESS: \_\_\_\_\_

PHONE NUMBER: \_\_\_\_\_

APPLICANTS NAME: \_\_\_\_\_

ADDRESS: \_\_\_\_\_

PHONE NUMBER: \_\_\_\_\_

EMAIL: \_\_\_\_\_

APPLICANTS SUGNITURE: x \_\_\_\_\_

WHEN WAS THE LAST TIME YOU TESTED YOUR SMOKE OR CARBON MONOXIDE DETECTORS??

## CHAPTER 439

The general municipal law is amended by adding a new section 125 to read as follows:

125. ISSUANCE OF BUILDING PERMITS. NO CITY, TOWN OR VILLAGE SHALL ISSUE A BUILDING PERMIT WITHOUT OBTAINING FROM THE PERMIT APPLICANT EITHER:

1. PROOF DULY SUBSCRIBED THAT WORKERS' COMPENSATION INSURANCE AND DISABILITY BENEFITS COVERAGE ISSUED BY AN INSURANCE CARRIER IN A FORM SATISFACTORY TO THE CHAIR OF THE WORKERS' COMPENSATION BOARD AS PROVIDED FOR IN SECTION FIFTY-SEVEN OF THE WORKERS' COMPENSATION LAW IS EFFECTIVE; OR

2. AN AFFIDAVIT THAT SUCH PERMIT APPLICANT HAS NOT ENGAGED AN EMPLOYER OR ANY EMPLOYEES AS THOSE TERMS ARE DEFINED IN SECTION TWO OF THE WORKERS' COMPENSATION LAW TO PERFORM WORK RELATING TO SUCH BUILDING PERMIT.

### Implementing Section 125 of the General Municipal Law

#### 1. General Contractors and Business Owners

For businesses listed as the general contractors on building permits, proof that they are in compliance with Section 57 of the Workers' Compensation Law (WCL) is ONE of the following forms that indicate that they are:

- ◆ insured (C-105.2 or U-26.3),
- ◆ self-insured (SI-12), or
- ◆ are exempt (C-105.21),

under the mandatory coverage provisions of the WCL. Any residence that is not a 1, 2, 3 or 4 Family, Owner-occupied Residence is considered a business (income or potential income property) and must prove compliance by filing one of the above forms.

#### 2. Owner-occupied Residences

For homeowners of a 1, 2, 3 or 4 Family, Owner-occupied Residence, proof of their exemption from the mandatory coverage provisions of the Workers' Compensation Law when applying for a building permit is to file form BP-1(3/99).

- ◆ Form BP-1(3/99) shall be filed if the homeowner of a 1, 2, 3 or 4 Family, Owner-occupied Residence is listed as the general contractor on the building permit, and the homeowner:
  - ◇ is performing all the work for which the building permit was issued him/herself,
  - ◇ is not hiring, paying or compensating in any way, the individual(s) that is(are) performing all the work for which the building permit was issued or helping the homeowner perform such work, or
  - ◇ has a homeowner's insurance policy that is currently in effect and covers the property for which the building permit was issued AND the homeowner is hiring or paying individuals a total of less than 40 hours per week (aggregate hours for all paid individuals on the jobsite) for the work for which the building permit was issued.
- ◆ If the homeowner of a 1, 2, 3 or 4 Family, Owner-occupied Residence is hiring or paying individuals a total of 40 hours or MORE in any week (aggregate hours for all paid individuals on the jobsite) for the work for which the building permit was issued, then the homeowner may not file the "Affidavit of Exemption" form, BP-1(3/99), but shall either:
  - ◇ acquire appropriate workers' compensation coverage and provide appropriate proof of that coverage on forms approved by the Chair of the NYS Workers' Compensation Board to the government entity issuing the building permit (the C-105.2 or U-26.3 form), OR
  - ◇ have the general contractor, (performing the work on the 1, 2, 3 or 4 family, owner-occupied residence (including condominiums) listed on the building permit) provide appropriate proof of workers' compensation coverage, or proof of exemption from that coverage on forms approved by the Chair of the NYS Workers' Compensation Board to the government entity issuing the building permit.

# Affidavit of Exemption to Show Specific Proof of Workers' Compensation Insurance Coverage for a 1, 2, 3 or 4 Family, Owner-occupied Residence

**Under penalty of perjury**, I certify that I am the owner of the 1, 2, 3 or 4 family, **owner-occupied** residence (including condominiums) listed on the building permit that I am applying for, and I am not required to show specific proof of workers' compensation insurance coverage for such residence because (please check the appropriate box):

- I am performing all the work for which the building permit was issued.
- I am not hiring, paying or compensating in any way, the individual(s) that is(are) performing all the work for which the building permit was issued or helping me perform such work.
- I have a homeowners insurance policy that is currently in effect and covers the property listed on the attached building permit AND am hiring or paying individuals a total of less than 40 hours per week (aggregate hours for all paid individuals on the jobsite) for which the building permit was issued.

I also agree to either:

- ◆ acquire appropriate workers' compensation coverage and provide appropriate proof of that coverage on forms approved by the Chair of the NYS Workers' Compensation Board to the government entity issuing the building permit if I need to hire or pay individuals a total of 40 hours or more per week (aggregate hours for all paid individuals on the jobsite) for work indicated on the building permit; OR
- ◆ have the general contractor, performing the work on the 1, 2, 3 or 4 family, **owner-occupied** residence (including condominiums) listed on the building permit that I am applying for, provide appropriate proof of workers' compensation coverage or proof of exemption from that coverage on forms approved by the Chair of the NYS Workers' Compensation Board to the government entity issuing the building permit if the project takes a total of 40 hours or more per week (aggregate hours for all paid individuals on the jobsite) for work indicated on the building permit.

\_\_\_\_\_  
(Signature of Homeowner)

\_\_\_\_\_  
(Date Signed)

\_\_\_\_\_  
(Homeowner's Name Printed)

Home Telephone Number \_\_\_\_\_

Property Address that requires the building permit:

\_\_\_\_\_  
\_\_\_\_\_  
\_\_\_\_\_  
\_\_\_\_\_

BP-1 (3/99)

<p><i>Sworn to before me this _____ day of</i></p> <p>_____, _____</p> <p><i>(County Clerk or Notary Public)</i></p>
--



# Critical Deck Connections Checklist

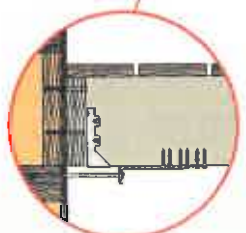

**Lateral-Load Connection**  
(p. 25)

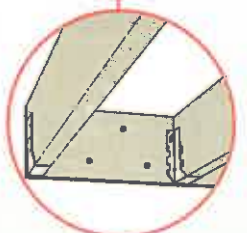

**Joist to Ledger**  
(p. 26)

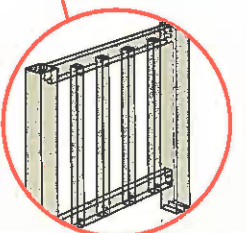

**Guardrail Infill Component Connections**  
(p. 34)

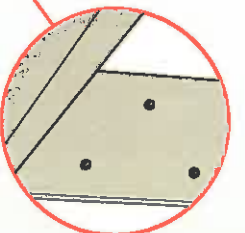

**Ledger Attachment**  
(p. 22)

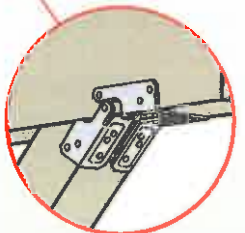

**Knee Brace**  
(p. 21)

# Critical Deck Connections Checklist

To build a safe, building code-compliant deck, it's essential that the deck design establish a continuous load path using a system of key connections throughout the deck framing. When this system of connections is made properly, loads are transferred through the deck frame and into the ground and/or the adjacent structure to which the deck is connected.

The connections shown below are necessary in order to create an effective continuous load path.

For information on the inspection of existing decks, see p. 10. For more information, please refer to the Deck Inspection for New and Existing Construction online training course at [strongtie.com/training](http://strongtie.com/training).

Use the diagram below to determine which deck connections may need retrofitting. For ledger connections to concrete and/or brick, see pp. 23–24.

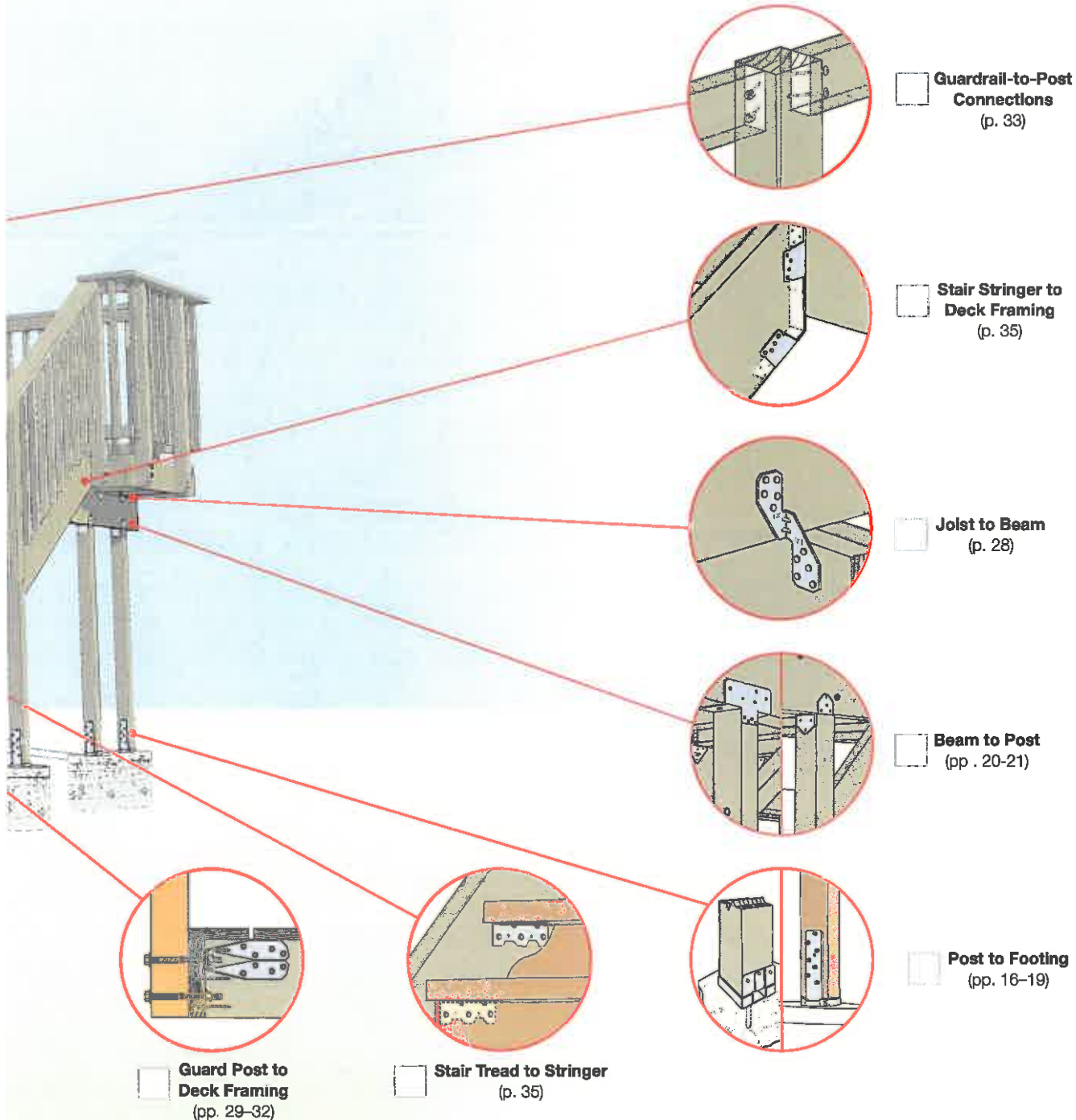

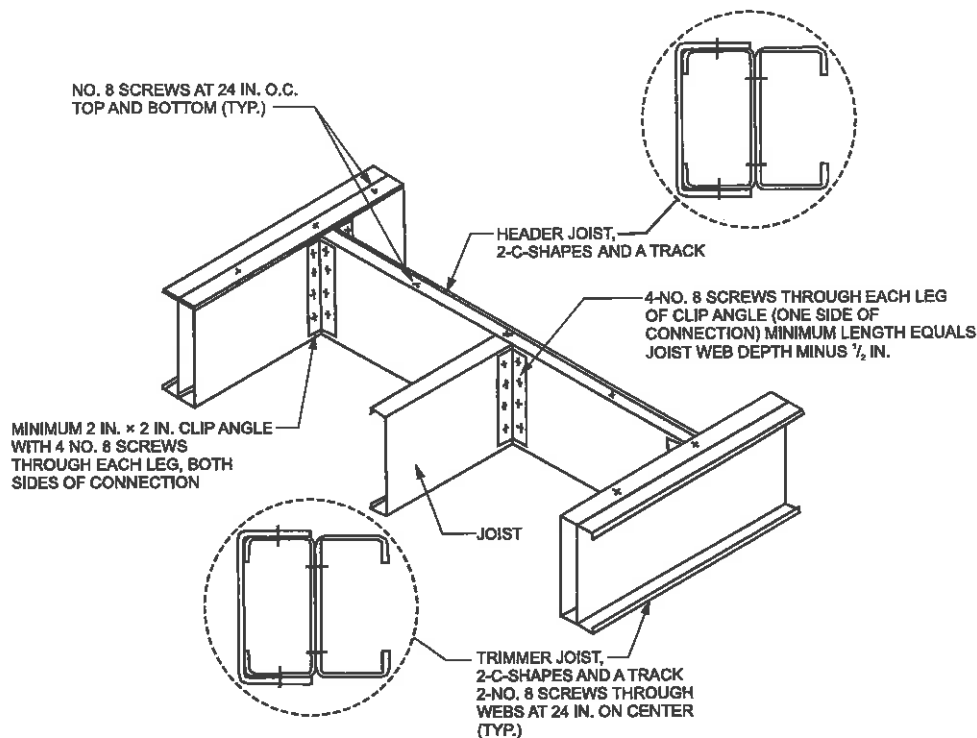

For SI: 1 inch = 25.4 mm, 1 foot = 304.8 mm.

FIGURE R505.3.8(4)  
COLD-FORMED STEEL FLOOR CONSTRUCTION: FLOOR HEADER TO TRIMMER CONNECTION—8-FOOT OPENING

## SECTION R506 CONCRETE FLOORS (ON GROUND)

**R506.1 General.** Concrete slab-on-ground floors shall be designed and constructed in accordance with the provisions of this section or ACI 332. Floors shall be a minimum 3<sup>1</sup>/<sub>2</sub> inches (89 mm) thick (for expansive soils, see Section R403.1.8). The specified compressive strength of concrete shall be as set forth in Section R402.2.

**R506.2 Site preparation.** The area within the foundation walls shall have all vegetation, top soil and foreign material removed.

**R506.2.1 Fill.** Fill material shall be free of vegetation and foreign material. The fill shall be compacted to ensure uniform support of the slab, and except where *approved*, the fill depths shall not exceed 24 inches (610 mm) for clean sand or gravel and 8 inches (203 mm) for earth.

**R506.2.2 Base.** A 4-inch-thick (102 mm) base course consisting of clean graded sand, gravel, crushed stone, crushed concrete or crushed blast-furnace slag passing a 2-inch (51 mm) sieve shall be placed on the prepared subgrade where the slab is below *grade*.

**Exception:** A base course is not required where the concrete slab is installed on well-drained or sand-gravel mixture soils classified as Group I according to the United Soil Classification System in accordance with Table R405.1.

**R506.2.3 Vapor retarder.** A 6-mil (0.006 inch; 152  $\mu$ m) polyethylene or *approved* vapor retarder with joints lapped not less than 6 inches (152 mm) shall be placed between the concrete floor slab and the base course or the prepared subgrade where a base course does not exist.

**Exception:** The vapor retarder is not required for the following:

1. Garages, utility buildings and other unheated *accessory structures*.
2. For unheated storage rooms having an area of less than 70 square feet (6.5 m<sup>2</sup>) and carports.
3. Driveways, walks, patios and other flatwork not likely to be enclosed and heated at a later date.
4. Where *approved* by the *building official*, based on local site conditions.

**R506.2.4 Reinforcement support.** Where provided in slabs-on-ground, reinforcement shall be supported to remain in place from the center to upper one-third of the slab for the duration of the concrete placement.



## SECTION R507 EXTERIOR DECKS



**R507.1 Decks.** Wood-framed decks shall be in accordance with this section. For decks using materials and conditions not prescribed in this section, refer to Section R301.

## FLOORS

**R507.2 Materials.** Materials used for the construction of decks shall comply with this section.

**R507.2.1 Wood materials.** Wood materials shall be No. 2 grade or better lumber, preservative-treated in accordance with Section R317, or *approved*, naturally durable lumber, and termite protected where required in accordance with Section R318. Where design in accordance with Section R301 is provided, wood structural members shall be designed using the wet service factor defined in AWC NDS. Cuts, notches and drilled holes of preservative-treated wood members shall be treated in accordance with Section R317.1.1. All preservative-treated wood products in contact with the ground shall be labeled for such usage.

**R507.2.1.1 Engineered wood products.** Engineered wood products shall be in accordance with Section R502.

**R507.2.2 Plastic composite deck boards, stair treads, guards, or handrails.** Plastic composite exterior deck boards, stair treads, guards and handrails shall comply with the requirements of ASTM D7032 and this section.

**R507.2.2.1 Labeling.** Plastic composite deck boards and stair treads, or their packaging, shall bear a label that indicates compliance with ASTM D7032 and includes the allowable load and maximum allowable span determined in accordance with ASTM D7032. Plastic or composite handrails and guards, or their packaging, shall bear a label that indicates compliance with ASTM D7032 and includes the maximum allowable span determined in accordance with ASTM D7032.

**R507.2.2.2 Flame spread index.** Plastic composite deck boards, stair treads, guards, and handrails shall exhibit a flame spread index not exceeding 200 when tested in accordance with ASTM E84 or UL 723 with the test specimen remaining in place during the test.

**Exception:** Plastic composites determined to be noncombustible.

**R507.2.2.3 Decay resistance.** Plastic composite deck boards, stair treads, guards and handrails containing wood, cellulosic or other biodegradable materials shall be decay resistant in accordance with ASTM D7032.

**R507.2.2.4 Termite resistance.** Where required by Section 318, plastic composite deck boards, stair treads, guards and handrails containing wood, cellulosic or other biodegradable materials shall be termite resistant in accordance with ASTM D7032.

**R507.2.2.5 Installation of plastic composites.** Plastic composite deck boards, stair treads, guards and handrails shall be installed in accordance with this code and the manufacturer's instructions.

**R507.2.3 Fasteners and connectors.** Metal fasteners and connectors used for all decks shall be in accordance with Section R317.3 and Table R507.2.3.

**R507.2.4 Flashing.** Flashing shall be corrosion-resistant metal of nominal thickness not less than 0.019 inch (0.48 mm) or *approved* nonmetallic material that is compatible with the substrate of the structure and the decking materials.

**R507.2.5 Alternate materials.** Alternative materials, including glass and metals, shall be permitted.

**R507.3 Footings.** Decks shall be supported on concrete footings or other approved structural systems designed to accommodate all loads in accordance with Section R301. Deck footings shall be sized to carry the imposed loads from the deck structure to the ground as shown in Figure R507.3. The footing depth shall be in accordance with Section R403.1.4.

**Exception:** Free-standing decks consisting of joists directly supported on grade over their entire length.

**R507.3.1 Minimum size.** The minimum size of concrete footings shall be in accordance with Table R507.3.1, based on the tributary area and allowable soil-bearing pressure in accordance with Table R401.4.1.

**TABLE R507.2.3**  
**FASTENER AND CONNECTOR SPECIFICATIONS FOR DECKS<sup>a,b</sup>**

ITEM	MATERIAL	MINIMUM FINISH/COATING	ALTERNATE FINISH/COATING <sup>a</sup>
Nails and timber rivets	In accordance with ASTM F1667	Hot-dipped galvanized per ASTM A153	Stainless steel, silicon bronze or copper
Bolts <sup>c</sup> Lag screws <sup>d</sup> (including nuts and washers)	In accordance with ASTM A307 (bolts), ASTM A563 (nuts), ASTM F844 (washers)	Hot-dipped galvanized per ASTM A153, Class C (Class D for $\frac{3}{8}$ -inch diameter and less) or mechanically galvanized per ASTM B695, Class 55 or 410 stainless steel	Stainless steel, silicon bronze or copper
Metal connectors	Per manufacturer's specification	ASTM A653 type G185 zinc coated galvanized steel or post hot-dipped galvanized per ASTM A123 providing a minimum average coating weight of 2.0 oz./ft <sup>2</sup> (total both sides)	Stainless steel

For SI: 1 inch = 25.4 mm, 1 foot = 304.8 mm.

- Equivalent materials, coatings and finishes shall be permitted.
- Fasteners and connectors exposed to salt water or located within 300 feet of a salt water shoreline shall be stainless steel.
- Holes for bolts shall be drilled a minimum  $\frac{1}{32}$  inch and a maximum  $\frac{1}{16}$  inch larger than the bolt.
- Lag screws  $\frac{1}{2}$  inch and larger shall be predrilled to avoid wood splitting per the National Design Specification (NDS) for Wood Construction.
- Stainless-steel-driven fasteners shall be in accordance with ASTM F1667.

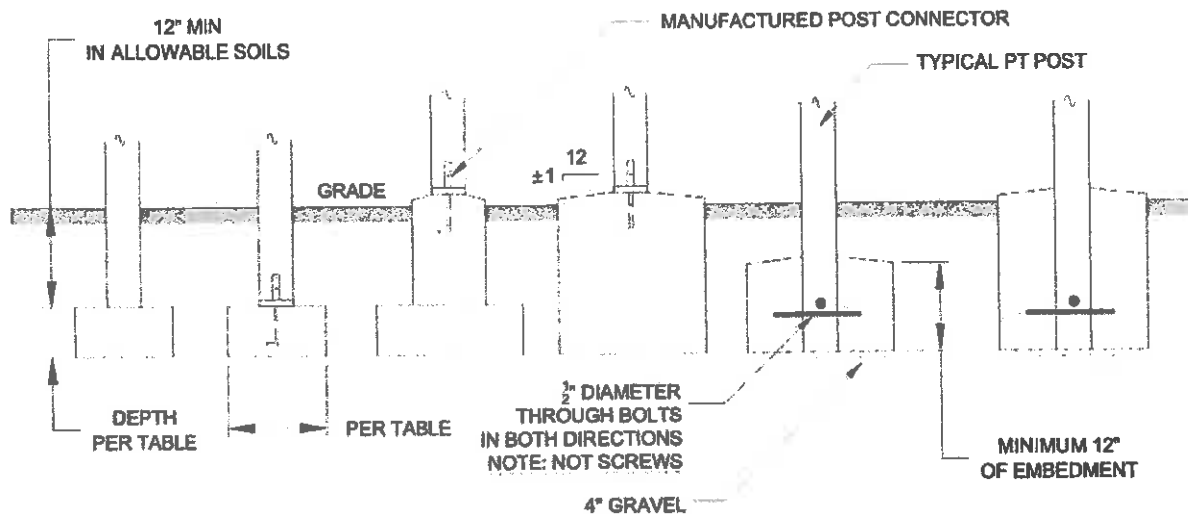

NOTE:  
POSTS MUST BE CENTERED ON OR IN FOOTING

For SI: 1 inch = 25.4 mm.

FIGURE R507.3  
DECK POSTS TO DECK FOOTING CONNECTION

**R507.3.2 Minimum depth.** Deck footings shall extend below the frost line specified in Table R301.2(1) in accordance with Section R403.1.4.1.

**Exceptions:**

1. Free-standing decks that meet all of the following criteria:
  - 1.1. The joists bear directly on precast concrete pier blocks at grade without support by beams or posts.
  - 1.2. The area of the deck does not exceed 200 square feet (18.9 m<sup>2</sup>).
  - 1.3. The walking surface is not more than 20 inches (616 mm) above grade at any point within 36 inches (914 mm) measured horizontally from the edge.
2. Free-standing decks need not be provided with footings that extend below the frost line.

**R507.4 Deck posts.** For single-level wood-framed decks with beams sized in accordance with Table R507.5, deck post size shall be in accordance with Table R507.4.

TABLE R507.4  
DECK POST HEIGHT<sup>a</sup>

DECK POST SIZE	MAXIMUM HEIGHT <sup>a,b</sup> (feet-inches)
4 × 4	6-9 <sup>c</sup>
4 × 6	8
6 × 6	14
8 × 8	14

For SI: 1 inch = 25.4 mm, 1 foot = 304.8 mm,  
1 pound per square foot = 0.0479 kPa.

- a. Measured to the underside of the beam.
- b. Based on 40 psf live load.
- c. The maximum permitted height is 8 feet for one-ply and two-ply beams. The maximum permitted height for three-ply beams on post cap is 6 feet 9 inches.

**R507.4.1 Deck post to deck footing connection.** Where posts bear on concrete footings in accordance with Section R403 and Figure R507.4.1, lateral restraint shall be provided by manufactured connectors or a minimum post embedment of 12 inches (305 mm) in surrounding soils or concrete piers. Other footing systems shall be permitted.

**Exception:** Where expansive, compressible, shifting or other questionable soils are present, surrounding soils shall not be relied on for lateral support.

**R507.5 Deck beams.** Maximum allowable spans for wood deck beams, as shown in Figure R507.5, shall be in accordance with Table R507.5. Beam plies shall be fastened with two rows of 10d (3-inch × 0.128-inch) nails minimum at 16 inches (406 mm) on center along each edge. Beams shall be permitted to cantilever at each end up to one-fourth of the allowable beam span. Deck beams of other materials shall be permitted where designed in accordance with accepted engineering practices.

FLOORS

TABLE R507.3.1  
MINIMUM FOOTING SIZE FOR DECKS

LIVE OR SNOW LOAD* (psf)	TRIBUTARY AREA (sq. ft.)	LOAD BEARING VALUE OF SOILS <sup>a,c,d</sup> (psf)														
		1500*				2000*				2500*				≥ 3000*		
		Side of a square footing (inches)	Diameter of a round footing (inches)	Thickness (inches)	Side of a square footing (inches)	Diameter of a round footing (inches)	Thickness (inches)	Side of a square footing (inches)	Diameter of a round footing (inches)	Thickness (inches)	Side of a square footing (inches)	Diameter of a round footing (inches)	Thickness (inches)			
40	20	12	14	6	12	14	6	12	14	6	12	14	6	12	14	6
	40	14	16	6	12	14	6	12	14	6	12	14	6	12	14	6
	60	17	19	6	15	17	6	13	15	6	12	14	6	12	14	6
	80	20	22	7	17	19	6	15	17	6	12	14	6	12	14	6
	100	22	25	8	19	21	6	17	19	6	12	14	6	12	14	6
	120	24	27	9	21	23	7	19	21	6	12	14	6	12	14	6
	140	26	29	10	22	25	8	20	23	7	18	21	6	12	14	6
	160	28	31	11	24	27	9	21	24	8	20	22	7	17	19	6
	20	12	14	6	12	14	6	12	14	6	12	14	6	12	14	6
	40	15	17	6	13	15	6	12	14	6	12	14	6	12	14	6
	60	19	21	6	16	18	6	14	16	6	12	14	6	12	14	6
	80	21	24	8	19	21	6	17	19	6	12	14	6	12	14	6
100	24	27	9	21	23	7	19	21	6	12	14	6	12	14	6	
120	26	30	10	23	26	8	20	23	7	19	21	6	12	14	6	
140	28	32	11	25	28	9	22	25	8	20	23	7	19	21	6	
160	30	34	12	26	30	10	24	27	9	21	24	8	20	22	7	
20	12	14	6	12	14	6	12	14	6	12	14	6	12	14	6	
40	16	19	6	14	16	6	13	15	6	12	14	6	12	14	6	
60	20	23	7	17	20	6	16	18	6	12	14	6	12	14	6	
80	23	26	9	20	23	7	18	20	6	12	14	6	12	14	6	
100	26	29	10	22	25	8	20	23	7	19	21	6	12	14	6	
120	28	32	11	25	28	9	22	25	8	20	23	7	19	21	6	
140	31	35	12	27	30	10	24	27	9	21	24	8	20	22	7	
160	33	37	13	28	32	11	25	29	10	22	25	9	21	24	8	
20	12	14	6	12	14	6	12	14	6	12	14	6	12	14	6	
40	18	20	6	15	17	6	14	15	6	12	14	6	12	14	6	
60	21	24	8	19	21	6	17	19	6	12	14	6	12	14	6	
80	25	28	9	21	24	8	19	22	7	18	21	6	12	14	6	
100	28	31	11	24	27	9	21	24	8	20	22	7	17	19	6	
120	30	34	12	26	30	10	24	27	9	21	24	8	20	22	7	
140	33	37	13	28	32	11	25	29	10	22	25	9	21	24	8	
160	35	40	15	30	34	12	27	31	11	23	26	10	22	25	9	

For SI: 1 inch = 25.4 mm, 1 square foot = 0.0929 m<sup>2</sup>, 1 pound per square foot = 0.0479 kPa.  
 a. Interpolation permitted, extrapolation not permitted.  
 b. Based on highest load case: Dead + Live or Dead + Snow.  
 c. Assumes minimum square footing to be 12 inches x 12 inches x 6 inches for 6 x 6 post.  
 d. If the support is a brick or CMU pier, the footing shall have a minimum 2-inch projection on all sides.  
 e. Area, in square feet, of deck surface supported by post and footings.

**R507.5.1 Deck beam bearing.** The ends of beams shall have not less than  $1\frac{1}{2}$  inches (38 mm) of bearing on wood or metal and not less than 3 inches (76 mm) of bearing on concrete or masonry for the entire width of the beam. Where multiple-span beams bear on intermediate posts, each ply must have full bearing on the post in accordance with Figures R507.5.1(1) and R507.5.1(2).

**R507.5.2 Deck beam connection to supports.** Deck beams shall be attached to supports in a manner capable of transferring vertical loads and resisting horizontal displacement. Deck beam connections to wood posts shall be in accordance with Figures R507.5.1(1) and R507.5.1(2). Manufactured post-to-beam connectors shall be sized for the post and beam sizes. Bolts shall have washers under the head and nut.

**R507.6 Deck joists.** Maximum allowable spans for wood deck joists, as shown in Figure R507.6, shall be in accordance with Table R507.6. The maximum joist spacing shall be limited by the decking materials in accordance with Table R507.7. The maximum joist cantilever shall be limited to one-fourth of the joist span or the maximum cantilever length specified in Table R507.6, whichever is less.

**R507.6.1 Deck joist bearing.** The ends of joists shall have not less than  $1\frac{1}{2}$  inches (38 mm) of bearing on wood or metal and not less than 3 inches (76 mm) of bearing on concrete or masonry over its entire width. Joists bearing on top of a multiple-ply beam or ledger shall be fastened in accordance with Table R602.3(1). Joists bearing on top of a single-ply beam or ledger shall be attached by a mechanical connector. Joist framing into the side of a beam or ledger board shall be supported by approved joist hangers.

**R507.6.2 Deck joist lateral restraint.** Joist ends and bearing locations shall be provided with lateral resistance to prevent rotation. Where lateral restraint is provided by joist hangers or blocking between joists, their depth shall equal not less than 60 percent of the joist depth. Where lateral restraint is provided by rim joists, they shall be secured to the end of each joist with not fewer than three 10d (3-inch by 0.128-inch) (76 mm by 3.3 mm) nails or three No. 10x 3-inch (76 mm) long wood screws.

**R507.7 Decking.** Maximum allowable spacing for joists supporting decking shall be in accordance with Table R507.7. Wood decking shall be attached to each supporting member with not less than two 8d threaded nails or two No. 8 wood screws. Other approved decking or fastener systems shall be installed in accordance with the manufacturer's installation requirements.

**R507.8 Vertical and lateral supports.** Where supported by attachment to an exterior wall, decks shall be positively anchored to the primary structure and designed for both vertical and lateral loads. Such attachment shall not be accom-

plished by the use of toenails or nails subject to withdrawal. For decks with cantilevered framing members, connection to exterior walls or other framing members shall be designed and constructed to resist uplift resulting from the full live load specified in Table R301.5 acting on the cantilevered portion of the deck. Where positive connection to the primary building structure cannot be verified during inspection, decks shall be self-supporting.

**R507.9 Vertical and lateral supports at band joist.** Vertical and lateral supports for decks shall comply with this section.

**R507.9.1 Vertical supports.** Vertical loads shall be transferred to band joists with ledgers in accordance with this section.

**R507.9.1.1 Ledger details.** Deck ledgers shall be a minimum 2-inch by 8-inch (51 mm by 203 mm) nominal, pressure-preservative-treated Southern pine, incised pressure-preservative-treated hem-fir, or approved, naturally durable, No. 2 grade or better lumber. Deck ledgers shall not support concentrated loads from beams or girders. Deck ledgers shall not be supported on stone or masonry veneer.

**R507.9.1.2 Band joist details.** Band joists supporting a ledger shall be a minimum 2-inch-nominal (51 mm), solid-sawn, spruce-pine-fir or better lumber or a minimum 1-inch by  $9\frac{1}{2}$ -inch (25 mm x 241 mm) dimensional, Douglas fir or better, laminated veneer lumber. Band joists shall bear fully on the primary structure capable of supporting all required loads.

**R507.9.1.3 Ledger to band joist details.** Fasteners used in deck ledger connections in accordance with Table R507.9.1.3(1) shall be hot-dipped galvanized or stainless steel and shall be installed in accordance with Table R507.9.1.3(2) and Figures R507.9.1.3(1) and R507.9.1.3(2).

**R507.9.1.4 Alternate ledger details.** Alternate framing configurations supporting a ledger constructed to meet the load requirements of Section R301.5 shall be permitted.

**R507.9.2 Lateral connection.** Lateral loads shall be transferred to the ground or to a structure capable of transmitting them to the ground. Where the lateral load connection is provided in accordance with Figure R507.9.2(1), hold-down tension devices shall be installed in not less than two locations per deck, within 24 inches (610 mm) of each end of the deck. Each device shall have an allowable stress design capacity of not less than 1,500 pounds (6672 N). Where the lateral load connections are provided in accordance with Figure R507.9.2(2), the hold-down tension devices shall be installed in not less than four locations per deck, and each device shall have an allowable stress design capacity of not less than 750 pounds (3336 N).

## FLOORS

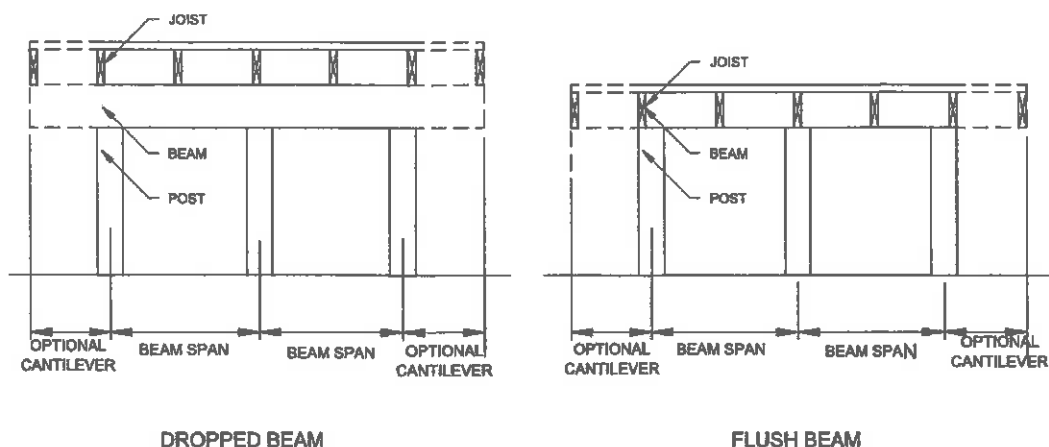

FIGURE R507.5  
TYPICAL DECK JOIST SPANS

TABLE R507.5  
DECK BEAM SPAN LENGTHS<sup>a, b, g</sup> (feet - inches)

SPECIES <sup>c</sup>	SIZE <sup>d</sup>	DECK JOIST SPAN LESS THAN OR EQUAL TO: (feet)						
		6	8	10	12	14	16	18
Southern pine	1-2 x 6	4-11	4-0	3-7	3-3	3-0	2-10	2-8
	1-2 x 8	5-11	5-1	4-7	4-2	2-10	3-7	3-5
	1-2 x 10	7-0	6-0	5-5	4-11	4-7	4-3	4-0
	1-2 x 12	8-3	7-1	6-4	5-10	5-5	5-0	4-9
	2-2 x 6	6-11	5-11	5-4	4-10	4-6	4-3	4-0
	2-2 x 8	8-9	7-7	6-9	6-2	5-9	5-4	5-0
	2-2 x 10	10-4	9-0	8-0	7-4	6-9	6-4	6-0
	2-2 x 12	12-2	10-7	9-5	8-7	8-0	7-6	7-0
	3-2 x 6	8-2	7-5	6-8	6-1	5-8	5-3	5-0
	3-2 x 8	10-10	9-6	8-6	7-9	7-2	6-8	6-4
	3-2 x 10	13-0	11-3	10-0	9-2	8-6	7-11	7-6
3-2 x 12	15-3	13-3	11-10	10-9	10-0	9-4	8-10	
Douglas fir-larch <sup>e</sup> , hem-fir <sup>e</sup> , spruce-pine-fir <sup>e</sup> , redwood, western cedars, ponderosa pine <sup>f</sup> , red pine <sup>f</sup>	3 x 6 or 2-2 x 6	5-5	4-8	4-2	3-10	3-6	3-1	2-9
	3 x 8 or 2-2 x 8	6-10	5-11	5-4	4-10	4-6	4-1	3-8
	3 x 10 or 2-2 x 10	8-4	7-3	6-6	5-11	5-6	5-1	4-8
	3 x 12 or 2-2 x 12	9-8	8-5	7-6	6-10	6-4	5-11	5-7
	4 x 6	6-5	5-6	4-11	4-6	4-2	3-11	3-8
	4 x 8	8-5	7-3	6-6	5-11	5-6	5-2	4-10
	4 x 10	9-11	8-7	7-8	7-0	6-6	6-1	5-8
	4 x 12	11-5	9-11	8-10	8-1	7-6	7-0	6-7
	3-2 x 6	7-4	6-8	6-0	5-6	5-1	4-9	4-6
	3-2 x 8	9-8	8-6	7-7	6-11	6-5	6-0	5-8
	3-2 x 10	12-0	10-5	9-4	8-6	7-10	7-4	6-11
3-2 x 12	13-11	12-1	10-9	9-10	9-1	8-6	8-1	

For SI: 1 inch = 25.4 mm, 1 foot = 304.8 mm, 1 pound per square foot = 0.0479 kPa, 1 pound = 0.454 kg.

a. Ground snow load, live load = 40 psf, dead load = 10 psf,  $L/\Delta = 360$  at main span,  $L/\Delta = 180$  at cantilever with a 220-pound point load applied at the end.

b. Beams supporting deck joists from one side only.

c. No. 2 grade, wet service factor.

d. Beam depth shall be greater than or equal to depth of joists with a flush beam condition.

e. Includes incising factor.

f. Northern species. Incising factor not included.

g. Beam cantilevers are limited to the adjacent beam's span divided by 4.



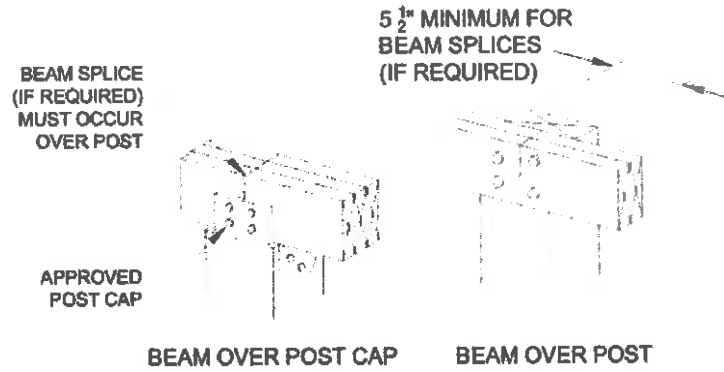

For SI: 1 inch = 25.4 mm.

FIGURE R507.5.1(1)  
DECK BEAM TO DECK POST

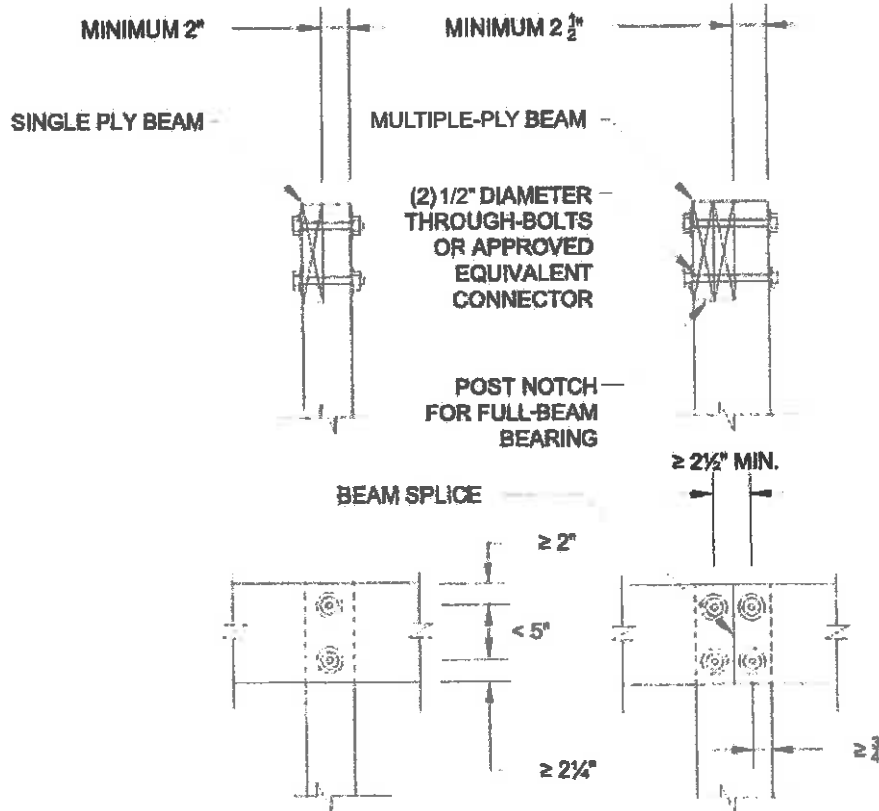

For SI: 1 inch = 25.4 mm.

FIGURE R507.5.1(2)  
NOTCHED POST-TO-BEAM CONNECTION

FLOORS

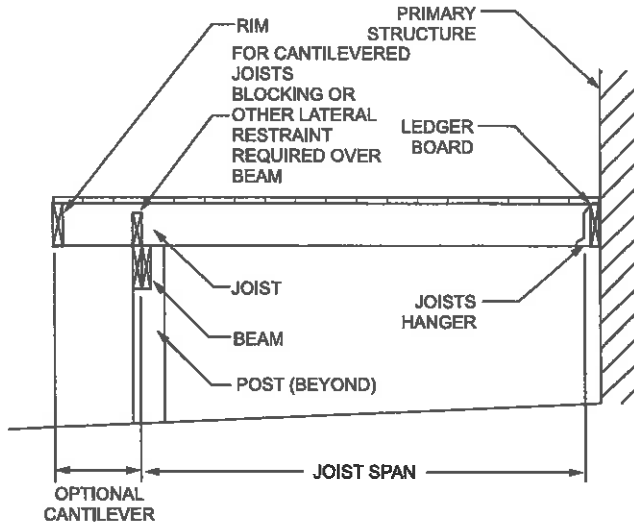

CANTILEVERED JOISTS WITH DROPPED BEAM

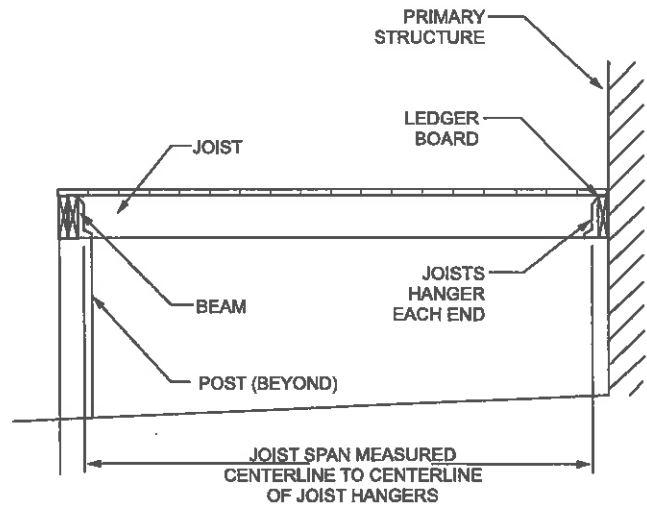

JOISTS WITH FLUSH BEAM

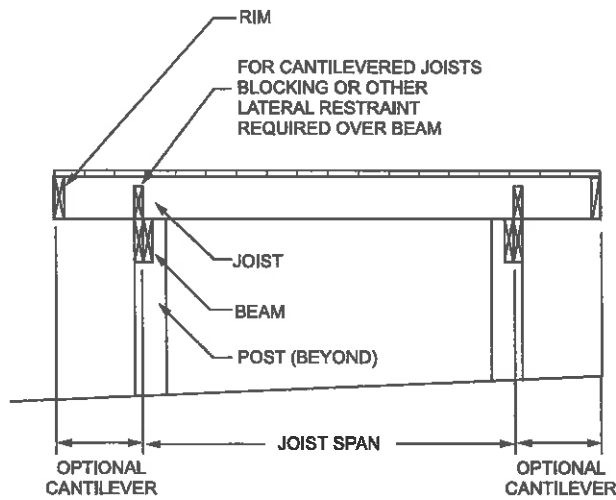

JOISTS ON FREE-STANDING DECK WITH DROPPED BEAM

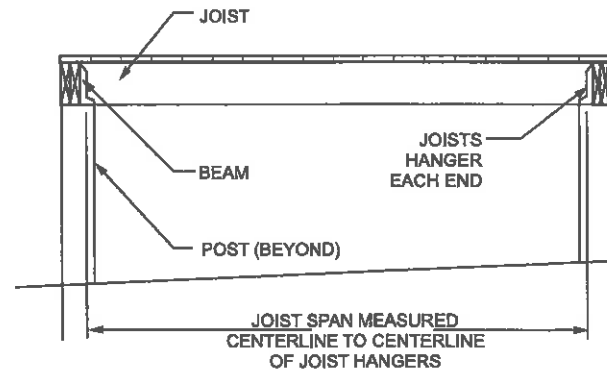

JOISTS ON FREE-STANDING DECK WITH FLUSH BEAM

FIGURE R507.6  
TYPICAL DECK JOIST SPANS

## FLOORS

TABLE R507.6  
DECK JOIST SPANS FOR COMMON LUMBER SPECIES (ft. - in.)

SPECIES <sup>a</sup>	SIZE	ALLOWABLE JOIST SPAN <sup>b</sup>			MAXIMUM CANTILEVER <sup>c,f</sup>		
		SPACING OF DECK JOISTS (inches)			SPACING OF DECK JOISTS WITH CANTILEVERS <sup>e</sup> (inches)		
		12	16	24	12	16	24
Southern pine	2 × 6	9-11	9-0	7-7	1-3	1-4	1-6
	2 × 8	13-1	11-10	9-8	2-1	2-3	2-5
	2 × 10	16-2	14-0	11-5	3-4	3-6	2-10
	2 × 12	18-0	16-6	13-6	4-6	4-2	3-4
Douglas fir-larch <sup>d</sup> , hem-fir <sup>d</sup> spruce-pine-fir <sup>d</sup> ,	2 × 6	9-6	8-8	7-2	1-2	1-3	1-5
	2 × 8	12-6	11-1	9-1	1-11	2-1	2-3
	2 × 10	15-8	13-7	11-1	3-1	3-5	2-9
	2 × 12	18-0	15-9	12-10	4-6	3-11	3-3
Redwood, western cedars, ponderosa pine <sup>e</sup> , red pine <sup>e</sup>	2 × 6	8-10	8-0	7-0	1-0	1-1	1-2
	2 × 8	11-8	10-7	8-8	1-8	1-10	2-0
	2 × 10	14-11	13-0	10-7	2-8	2-10	2-8
	2 × 12	17-5	15-1	12-4	3-10	3-9	3-1

For SI: 1 inch = 25.4 mm, 1 foot = 304.8 mm, 1 pound per square foot = 0.0479 kPa, 1 pound = 0.454 kg.

- No. 2 grade with wet service factor.
- Ground snow load, live load = 40 psf, dead load = 10 psf,  $L/\Delta = 360$ .
- Ground snow load, live load = 40 psf, dead load = 10 psf,  $L/\Delta = 360$  at main span,  $L/\Delta = 180$  at cantilever with a 220-pound point load applied to end.
- Includes incising factor.
- Northern species with no incising factor.
- Cantilevered spans not exceeding the nominal depth of the joist are permitted.

TABLE R507.7  
MAXIMUM JOIST SPACING FOR DECKING

DECKING MATERIAL TYPE AND NOMINAL SIZE	MAXIMUM ON-CENTER JOIST SPACING	
	Decking perpendicular to joist	Decking diagonal to joist <sup>a</sup>
1 $\frac{1}{4}$ -inch-thick wood	16 inches	12 inches
2-inch-thick wood	24 inches	16 inches
Plastic composite	In accordance with Section R507.2	In accordance with Section R507.2

For SI: 1 inch = 25.4 mm, 1 foot = 304.8 mm, 1 degree = 0.01745 rad.

- Maximum angle of 45 degrees from perpendicular for wood deck boards.

## FLOORS

**TABLE R507.9.1.3(1)**  
**DECK LEDGER CONNECTION TO BAND JOIST<sup>a, b</sup>**  
 (Deck live load = 40 psf, deck dead load = 10 psf, snow load ≤ 40 psf)

CONNECTION DETAILS	JOIST SPAN						
	6' and less	6'1" to 8'	8'1" to 10'	10'1" to 12'	12'1" to 14'	14'1" to 16'	16'1" to 18'
	On-center spacing of fasteners						
1/2-inch diameter lag screw with 1/2-inch maximum sheathing <sup>a, d</sup>	30	23	18	15	13	11	10
1/2-inch diameter bolt with 1/2-inch maximum sheathing <sup>d</sup>	36	36	34	29	24	21	19
1/2-inch diameter bolt with 1-inch maximum sheathing <sup>e</sup>	36	36	29	24	21	18	16

For SI: 1 inch = 25.4 mm, 1 foot = 304.8 mm, 1 pound per square foot = 0.0479 kPa.

- Ledgers shall be flashed in accordance with Section R703.4 to prevent water from contacting the house band joist.
- Snow load shall not be assumed to act concurrently with live load.
- The tip of the lag screw shall fully extend beyond the inside face of the band joist.
- Sheathing shall be wood structural panel or solid sawn lumber.
- Sheathing shall be permitted to be wood structural panel, gypsum board, fiberboard, lumber or foam sheathing. Up to 1/2-inch thickness of stacked washers shall be permitted to substitute for up to 1/2 inch of allowable sheathing thickness where combined with wood structural panel or lumber sheathing.

**TABLE R507.9.1.3(2)**  
**PLACEMENT OF LAG SCREWS AND BOLTS IN DECK LEDGERS AND BAND JOISTS**

	MINIMUM END AND EDGE DISTANCES AND SPACING BETWEEN ROWS			
	TOP EDGE	BOTTOM EDGE	ENDS	ROW SPACING
Ledger <sup>a</sup>	2 inches <sup>d</sup>	3/4 inch	2 inches <sup>b</sup>	1 5/8 inches <sup>b</sup>
Band Joist <sup>c</sup>	3/4 inch	2 inches	2 inches <sup>b</sup>	1 5/8 inches <sup>b</sup>

For SI: 1 inch = 25.4 mm.

- Lag screws or bolts shall be staggered from the top to the bottom along the horizontal run of the deck ledger in accordance with Figure R507.9.1.3(1).
- Maximum 5 inches.
- For engineered rim joists, the manufacturer's recommendations shall govern.
- The minimum distance from bottom row of lag screws or bolts to the top edge of the ledger shall be in accordance with Figure R507.9.1.3(1).

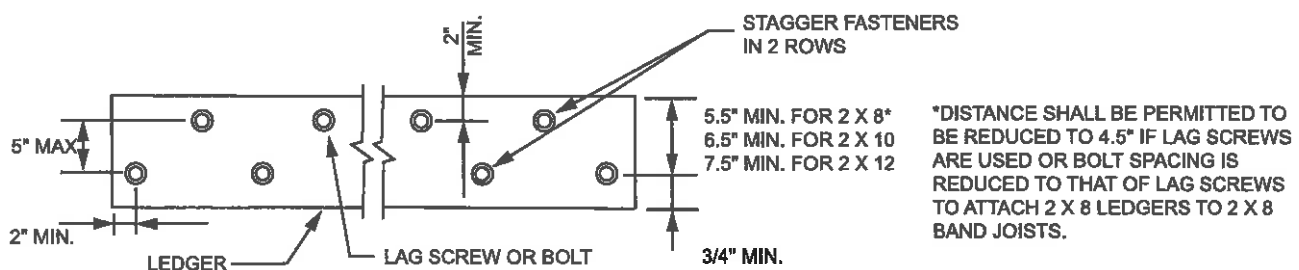

For SI: 1 inch = 25.4 mm.

**FIGURE R507.9.1.3(1)**  
**PLACEMENT OF LAG SCREWS AND BOLTS IN LEDGERS**

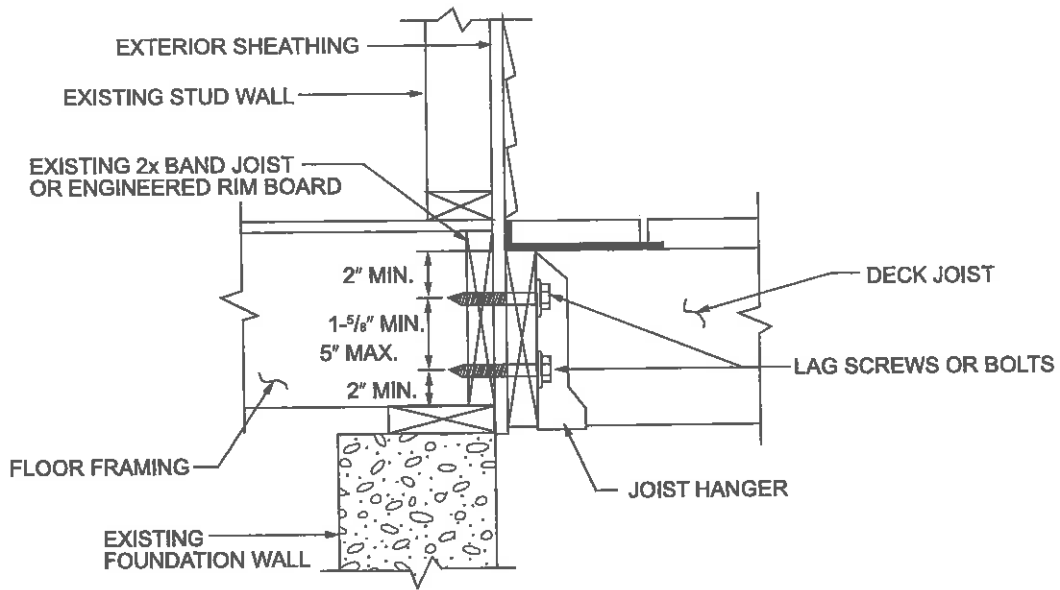

For SI: 1 inch = 25.4 mm.

**FIGURE R507.9.1.3(2)**  
**PLACEMENT OF LAG SCREWS AND BOLTS IN BAND JOISTS**

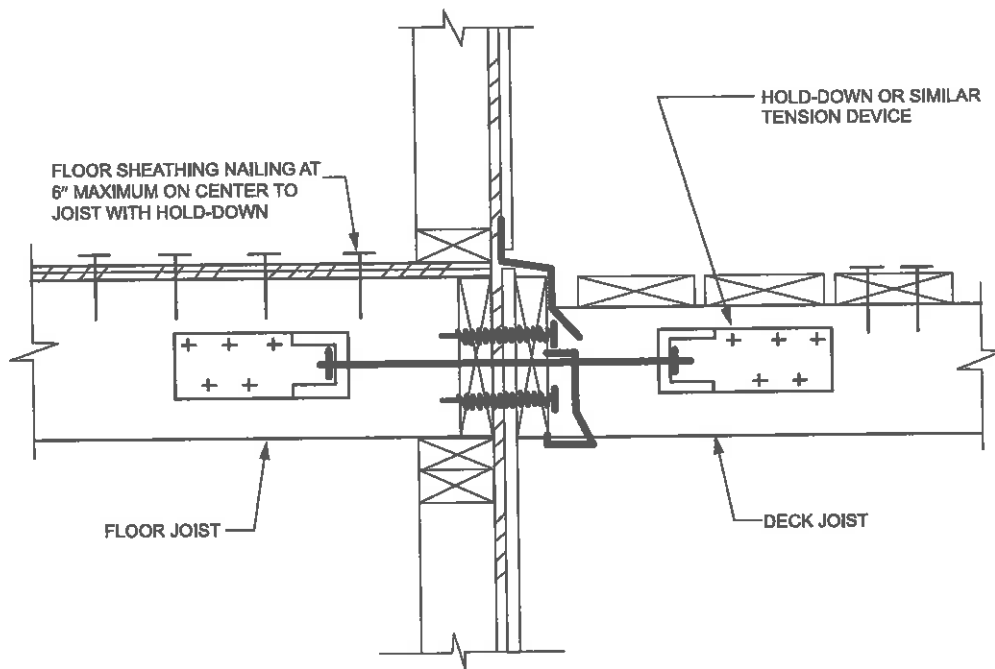

For SI: 1 inch = 25.4 mm.

**FIGURE R507.9.2(1)**  
**DECK ATTACHMENT FOR LATERAL LOADS**

## FLOORS

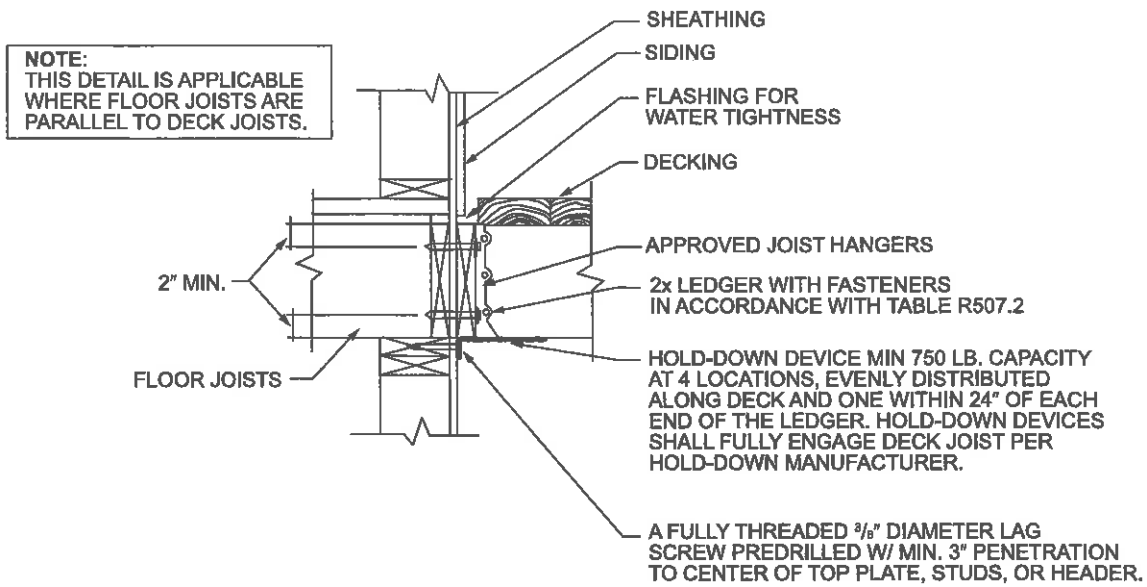

For SI: 1 inch = 25.4 mm, 1 foot = 304.8 mm.

**FIGURE R507.9.2(2)**  
**DECK ATTACHMENT FOR LATERAL LOADS**